

# General Plant

## Overview

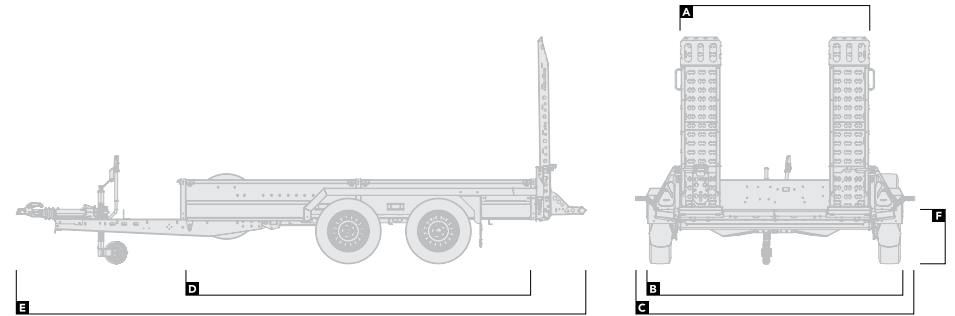

		551-	2713-27-2-13	2716-27-2-13	3116-27-2-13	3117-35-2-13	3617-35-2-13	3618-35-3-12	4017-35-2-13	4018-35-3-12
<b>DIMENSIONS</b>		dimensions in metres								
Bed width	<b>A</b>	1.3	1.6	1.6	1.7	1.7	1.7	1.8	1.7	1.8
Overall width (excl. marker lamp)	<b>B</b>	1.91	2.21	2.21	2.31	2.31	2.31	2.41	2.31	2.41
Overall width (inc. marker lamp)	<b>C</b>	-	2.4	2.4	2.5	2.5	2.5	2.6	2.5	2.6
Bed length	<b>D</b>	2.8	2.8	3.2	3.2	3.7	3.7	3.7	4.1	4.1
Overall length	<b>E</b>	4.4	4.4	4.8	4.8	5.3	5.3	5.3	5.7	5.7
Bed height	<b>F</b>	0.45	0.45	0.45	0.43	0.43	0.43	0.43	0.43	0.43
<b>CAPACITY</b>		weight in kg								
Gross capacity		2,700	2,700	2,700	3,500	3,500	3,500	3,500	3,500	3,500
Load capacity		2,113	2,063	2,031	2,766	2,717	2,646	2,698	2,698	2,623

Load capacity will vary depending on options fitted - For accurate information on weights and pricing, use our interactive configurator at [www.brianjamestrailers.co.uk](http://www.brianjamestrailers.co.uk)

